

FRESA LIVELLATRICE

MTZ 100-120-135-150-170

MTZ_{HI} 100-120-135-150-170

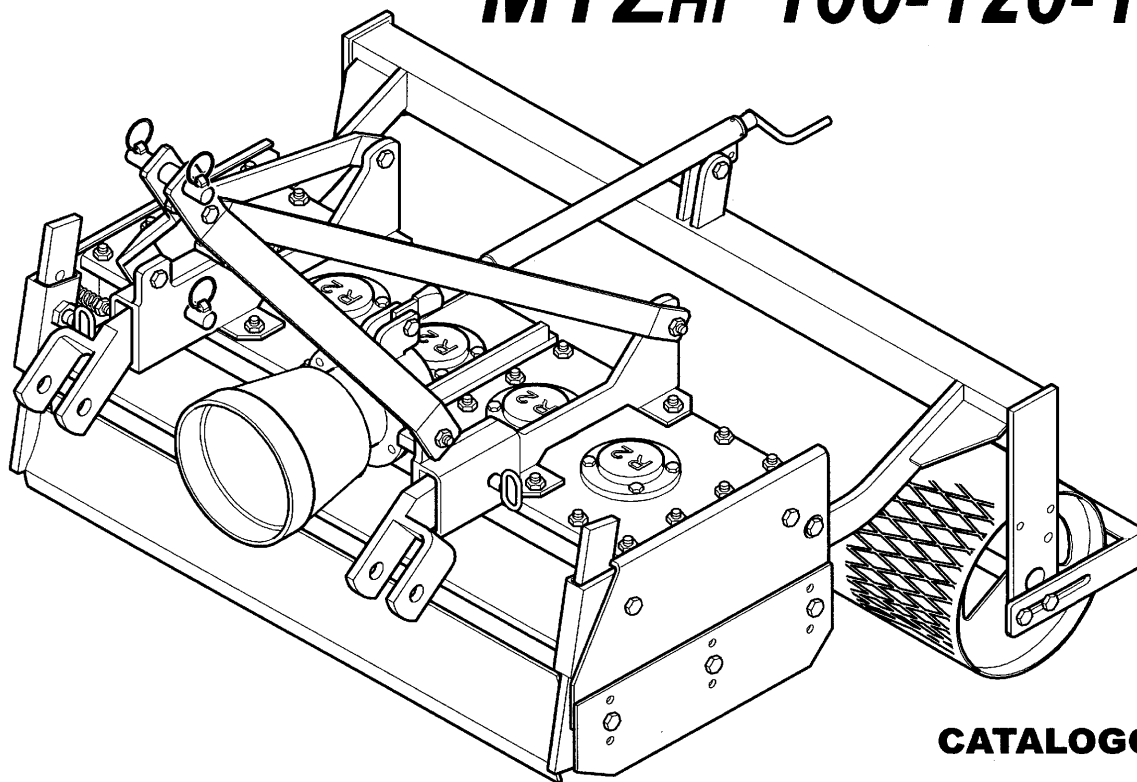

R2 s.a.s. di Rinaldi Roberto & C.

40060 Toscanella di Dozza (Bologna) Italy - Via Valsellustra, 25-29

Tel. +39.0542.672100 • Fax +39.0542.674391

CATALOGO PARTI DI RICAMBIO

SPARE PARTS CATALOGUE

CATALOGUE DE PIÈCES DÉTACHÉES

ERSATZTEILKATALOG

CATALOGO DE PIEZAS DE REPUESTO

Cod. **034** rev.0

Edizione 07/2007

SIMBOLOGIA • SYMBOLS • SYMBOLES UTILISES • SYMBOLE • SIMBOLOGIA

I

Nella colonna CODICE di ogni distinta può essere presente uno di questi simboli:



Parte di ricambio momentaneamente priva di codice.

Per identificarla occorre indicare:

- Numero della tavola
- Numero di posizione
- Modello e matricola della macchina.



Parte di ricambio avente ulteriori parti di ricambio interne.

Per identificare le singole parti interne occorre andare alla tavola di corrispondente denominazione.



Parte di ricambio con variabili dimensionali o di quantità.

Occorre specificare il modello e la matricola della macchina individuabili nell'apposita targhetta.

GB

In the CODED column of each list, you find one of following symbols:



Spare part temporarily uncoded.

To identify the part you must specify:

- Table code
- Position number
- Machine model and serial number.



Spare part consisting of more internal spare parts.

To find the single internal parts, please refer to the relevant description table.



Spare part with dimension or quantity variables.

Always specify the machine model and serial number, given in the identification plate.

F

Dans la colonne CODE de chaque liste Vous pouvez trouver un des symboles suivants:



Pièce de réchange temporairement sans code.

Pour son identification, il faut spécifier:

- Code du tableau
- Numéro de position
- Modèle et numéro de fabrication machine.



Pièce de réchange comprenant des pièces de rechange à l'intérieur.

Pour l'identification de pièces individuelles, se référer au tableau descriptif correspondant.



Pièce détachée avec variables dimensionnelles o de quantité.

Spécifier toujours le modèle et le numéro de fabrication de la machine, donnés sur la plaque d'identification.

D

Die Reihe Anmerkungen jeder CODE kann einfolgender Symbole zeigen:



Ersatzteil hat vorübergehend keinen Code.

Um diesen Ersatzteil angeben zu können, müssen Sie:

- Code Tabelle
- Positionsnummer
- Maschinenmodell und -kennnummer.



Ersatzteil hat weitere Ersatzteile auf der Innenseite.

Für die Identifikation der einzelnen Innerteile, die entsprechende Benennungstabelle nachschlagen.



Ersatzteil mit variablen Maßen oder Menge.

Bitte, Modell und Fabriknummer der Maschine, die auf dem Typenschild abgedruckt sind, angeben.

E

La columna CÓDIGO de cada lista puede presentar uno de los símbolos siguientes:



Repuesto actualmente falto de código.

Para la identificación del repuesto es necesario indicar:

- Código tabla
- Número de posición
- Modelo y número de serie máquina.



Repuesto que consta de sucesivos repuestos internos.

Para la identificación de las partes internas distintas, ver tabla descriptiva correspondiente.



Repuesto con variables dimensionales o de cantidad.

Declarar siempre el modelo y el número de serie de la máquina, que se encuentran en la tarjeta de identificación.

COME ORDINARE I RICAMBI • HOW TO ORDER SPARE PARTS • COMMANDE DES PIÈCES DÉTACHÉES • ANFRANGE VON ERSATZTEILEN • PEDIDO DE LOS REPUESTOS

Per ordinare le parti di ricambio Vi preghiamo cortesemente di fornire al Servizio Assistenza tutte le seguenti informazioni:

- Modello, tipo e numero di matricola della macchina.
- Codice, descrizione e quantità delle parti di ricambio che si intendono ordinare.

Inoltre all'ordine sarà necessario precisare:

- Ragione sociale, indirizzo completo, recapito telefonico e telefax.
- Indirizzo completo al quale spedire le parti di ricambio.
- Eventuale mezzo di trasporto/vettore da utilizzare preferenzialmente.

When ordering spare parts, please supply After Sales Service the following information:

- Machine model, type and serial number
- Code, description and quantity of the spare parts you wish to order.

In addition to what above, add also:

- Corporate name, address, phone and fax number.
- Delivery address.
- Preferential transport mean/carrier.

Pour commander les pièces de rechange nous vous prions de bien vouloir transmettre au Service Après-Vente les indications suivantes:

- Modèle, type et numéro de série de la machine.
- Code, description et quantité des pièces de rechange commandées.

De plus, indiquer dans la commande:

- Nom de la société, adresse complète, numéro de téléphone et de télécopieur.
- Adresse complète pour l'expédition.
- Eventuel moyen de transport/expéditeur préférentiel.

Um Ersatzteil zu bestellen, bitten wir Sie höflichst, dem Kundendienst alle nachfolgend angeführten Angaben zu machen:

- Modell, Typ und Matrikel-Nr. der Maschine.
- Code, Beschreibung und Anzahl der Ersatzteile, die man bestellen möchte.

Außerdem sollte man bei der Bestellung angeben:

- Name der Firma, vollständige Adresse, Telefon und Faxnummer.
- Vollständige Adresse, an die Ersatzteile zu senden sind.
- Von Ihnen gewünschtes Transportmittel / Transportunternehmen.

Para el pedido de repuestos, Le rogamos se sirvan suministrar al Servicio Asistencia todas las indicaciones siguientes:

- Modelo, tipo y número de matrícula de la máquina.
- Código, descripción y cantidad de los repuestos pedido.

Además, se ruega detallar lo siguiente:

- Razón social, dirección completa, teléfono y telefax.
- Dirección completa a la que se deben enviar los repuestos.
- Eventual medio/agente de transporte que se desea utilizar.

INDICE DELLE TAVOLE • TABLE INDEX • INDEX DES TABLEAUX

01.0	GRUPPO PALA E RULLO (MTZ 100-120)	SHOVEL AND ROLLER GROUP (MTZ 100-120)	GROUPE PELLE ET ROULEAU (MTZ 100-120)
02.0	GRUPPO PALA E RULLO (MTZ 120-135-150-170)	SHOVEL AND ROLLER GROUP (MTZ 120-135-150-170)	GROUPE PELLE ET ROULEAU (MTZ 120-135-150-170)
03.0	TELAIO E ACCESSORI	FRAME AND ACCESSORIES	CHASSIS ET ACCESSOIRES
04.0	TRASMISSIONE (MTZ 100-120)	TRANSMISSION (MTZ 100-120)	TRANSMISSION (MTZ 100-120)
05.0	TRASMISSIONE (MTZ 120-135-150-170)	TRANSMISSION (MTZ 120-135-150-170)	TRANSMISSION (MTZ 120-135-150-170)
06.0	TRASMISSIONE IDRAULICA (MTZ _{HI})	HYDRAULIC TRANSMISSION (MTZ _{HI})	TRANSMISSION HIDRAULIQUE (MTZ _{HI})
07.0	KIT RULLO A GABBIA	CAGE ROLLER KIT	KIT ROULEAU A CAGE
08.0	KIT RULLO PIENO	PLAIN ROLLER KIT	KIT ROULEAU PLEIN

TABELLEN-VERZEICHNIS • INDICE DE LAS TABLAS

01.0	SCHAUFEL UND WALZEN GRUPPE (MTZ 100-120)	GRUPO PALA Y RODILLO (MTZ 100-120)
02.0	SCHAUFEL UND WALZEN GRUPPE (MTZ 120-135-150-170)	GRUPO PALA Y RODILLO (MTZ 120-135-150-170)
03.0	RAHMEN UND ZEBÖHR	BASTIDOR Y ACCESORIOS
04.0	TRANSMISSION (MTZ 100-120)	TRANSMISIÓN (MTZ 100-120)
05.0	TRANSMISSION (MTZ 120-135-150-170)	TRANSMISIÓN (MTZ 120-135-150-170)
06.0	HYDRAULIKANTRIEB (MTZ _{HI})	TRANSMISIÓN HIDRÁULICA (MTZ _{HI})
07.0	KAFIGWALZENKIT	KIT RODILLO A JAULA
08.0	VOLLWALZENKIT	KIT RODILLO LLANO



GRUPPO PALA E RULLO (MTZ 100-120)
SHOVEL AND ROLLER GROUP (MTZ 100-120)
GROUPE PELLE ET ROULEAU (MTZ 100-120)
SCHAUFEL UND WALZEN GRUPPE (MTZ 100-120)
GRUPO PALA Y RODILLO (MTZ 100-120)

Tav. 01.0

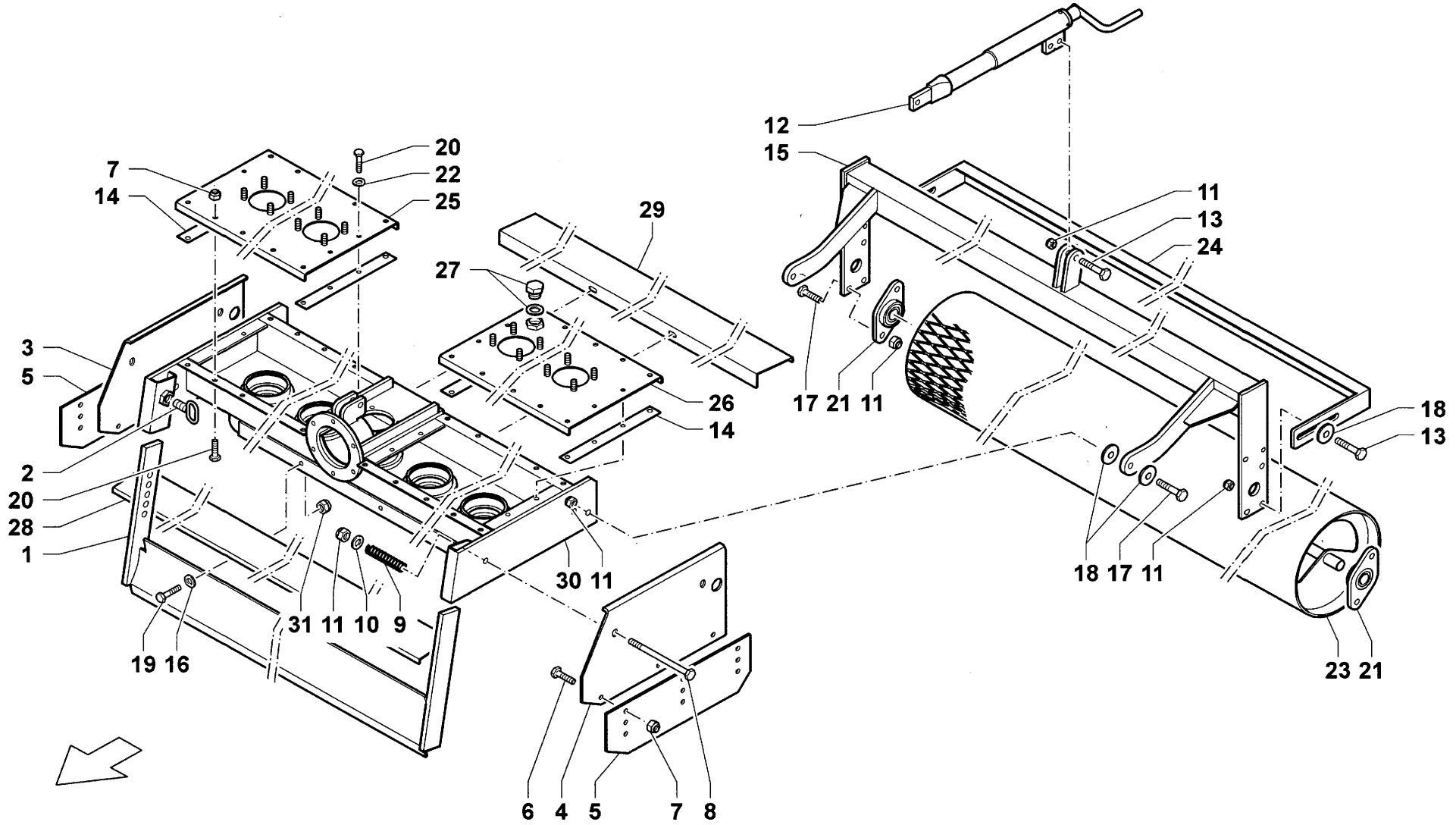

<i>Rif.</i>	<i>CODICE</i>	<i>Qnt</i>	<i>Descrizione</i>	<i>Description</i>	<i>Designation</i>	<i>Benennung</i>	<i>Denominaciones</i>
1	031.035	1	RUSPETTA MTZ-100	LEVELLING BAR	BARRE NIVELEUSE	PLANIERSTANGE	BARRA NIVELADORA
1	034.005	1	RUSPETTA MTZ-120	LEVELLING BAR	BARRE NIVELEUSE	PLANIERSTANGE	BARRA NIVELADORA
2	000.001	2	FRULLETTO	THREADED PIN	AXE TARAUDE	GEWINDEBOLZEN	PERNO CON ROSCA
3	000.003	1	FIANCHETTO DX	RIGHT SIDE	COTE DROIT	SEITENWAND RECHTS	CÀRTER DERECHO
4	000.004	1	FIANCHETTO SX	LEFT SIDE	COTE GAUCHE	SEITENWAND LINKS	CÀRTER IZQUIERDO
5	000.005	1	PROLUNGA	EXTENSION	RALLONGE	VERLÄNGERUNG	PROLONGA
6	21.0.0.08016	6	VITE	SCREW	VIS	SCHRAUBE	TORNILLO
7	30.02.00.008	32	DADO AUTOBLOCCANTE	STOP NUT	ECROU DE SURETE	SPERRMUTTER	TUERCA AUTOTRABADORA
8	20.0.0.10100	4	VITE	SCREW	VIS	SCHRAUBE	TORNILLO
9	000.011	4	MOLLA	SPRING	RESSORT	FEDER	RESORTE
10	15.0.0.00.010	4	RONDELLA	WASHER	RONDELLE	SCHEIBE	ARANDELA
11	30.02.00.010	11	DADO AUTOBLOCCANTE	STOP NUT	ECROU DE SURETE	SPERRMUTTER	TUERCA AUTOTRABADORA
12	034.070	1	REGISTRO	ADJUSTER	REGLAGE	REGULATOR	AJUSTE
13	21.0.0.10045	3	VITE	SCREW	VIS	SCHRAUBE	TORNILLO
14	050.074	4	GUARNIZIONE	SEAL	JOINT	DICHTUNG	GUARNICIÓN
15	031.030	1	SUPPORTO RULLO MTZ-100	SUPPORT	SUPPORT	LAGER	SOPORTE
15	034.006	1	SUPPORTO RULLO MTZ-120	SUPPORT	SUPPORT	LAGER	SOPORTE
16	15.0.0.00.008	8	RONDELLA	WASHER	RONDELLE	SCHEIBE	ARANDELA
17	21.0.0.10035	6	VITE	SCREW	VIS	SCHRAUBE	TORNILLO
18	15.1.0.00.010	4	RONDELLA	WASHER	RONDELLE	SCHEIBE	ARANDELA
19	21.0.0.08020	8	VITE	SCREW	VIS	SCHRAUBE	TORNILLO
20	21.0.0.08016	32	VITE	SCREW	VIS	SCHRAUBE	TORNILLO
21	BUCFL204	2	SUPPORTO	SUPPORT	SUPPORT	LAGER	SOPORTE
22	16.00.00.008	8	RONDELLA ELASTICA	SPRING WASHER	RONDELLE ELASTIQUE	FEDERSCHEIBE	ARANDELA ELASTICA
23	031.039	1	RULLO MTZ-100	ROLLER	ROULEAU	WALZE ROLLE	RODILLO
23	034.007	1	RULLO MTZ-120	ROLLER	ROULEAU	WALZE ROLLE	RODILLO
24	031.032	1	PULISCI RULLO MTZ-100	ROLLER CLEANER	NETTOYEUR ROULEAU	WALZENREINIGER	LIMPIADOR RODILLO
24	034.015	1	PULISCI RULLO MTZ-120	ROLLER CLEANER	NETTOYEUR ROULEAU	WALZENREINIGER	LIMPIADOR RODILLO
25	031.049/A	1	COPERCHIO DX MTZ-100	RIGHT COVER	COUVERCLE DROIT	DECKEL RECHTS	TAPA DERECHA
25	034.004/A	1	COPERCHIO DX MTZ-120	RIGHT COVER	COUVERCLE DROIT	DECKEL RECHTS	TAPA DERECHA
26	031.049/B	1	COPERCHIO SX MTZ-100	LEFT COVER	COUVERCLE GAUCHE	DECKEL LINKS	TAPA IZQUIERDO

Tav. 01.0





GRUPPO PALA E RULLO (MTZ 100-120)
SHOVEL AND ROLLER GROUP (MTZ 100-120)
GROUPE PELLE ET ROULEAU (MTZ 100-120)
SCHAUFEL UND WALZEN GRUPPE (MTZ 100-120)
GRUPO PALA Y RODILLO (MTZ 100-120)

Tav. 01.0

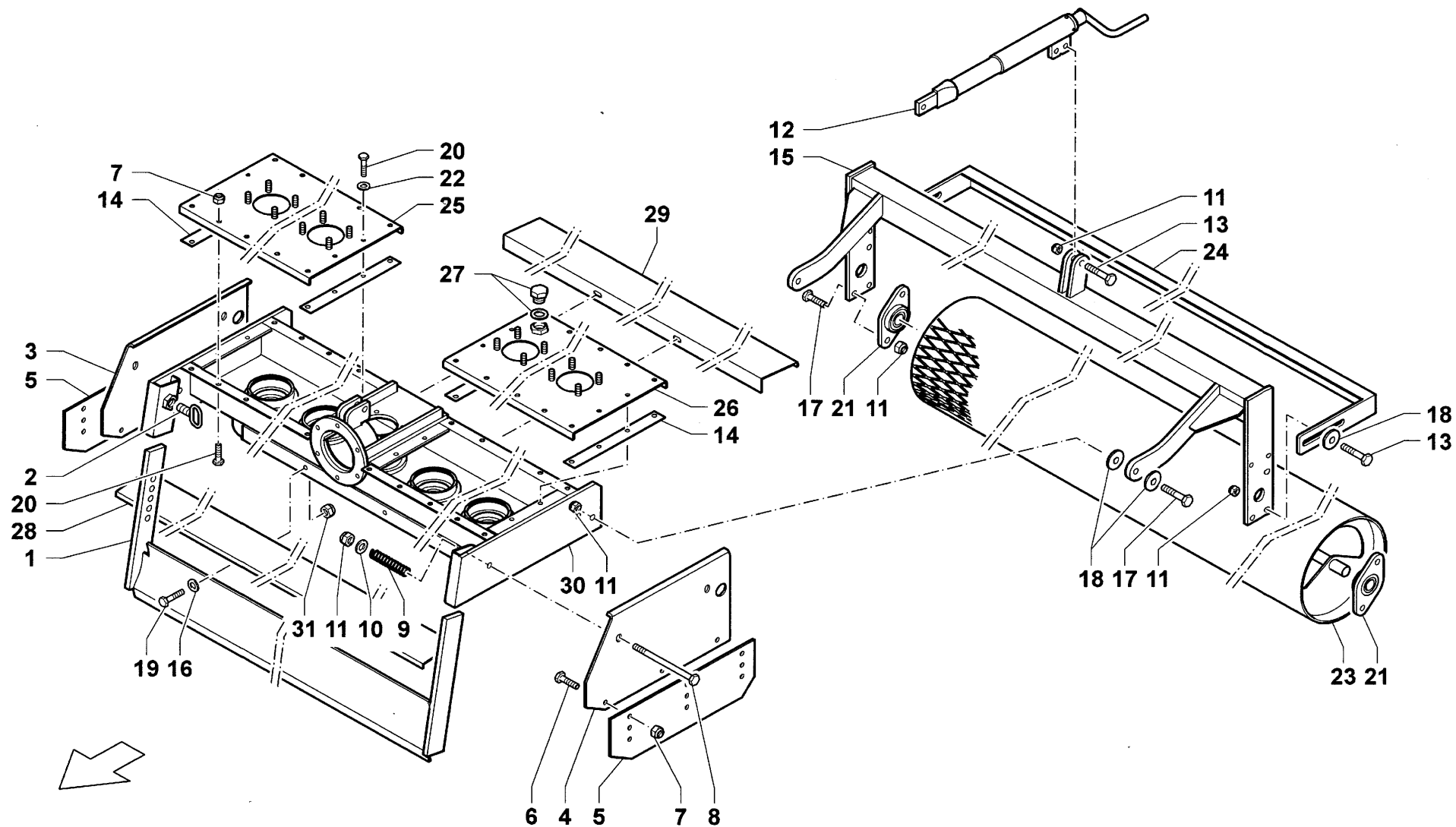

Rif.	CODICE	Qty	Descrizione	Description	Designation	Benennung	Denominaciones
26	034.004/B	1	COPERCHIO SX MTZ-120	LEFT COVER	COUVERCLE GAUCHE	DECKEL LINKS	TAPA IZQUIERDO
27	050.001	1	TAPPO	PLUG	BOUCHON	STOPFEN	TAPÓN
28	031.065	1	PROTEZIONE MTZ-100	GUARD	PROTECTION	SCHUTZ	PROTECCION
28	034.211	1	PROTEZIONE MTZ-120	GUARD	PROTECTION	SCHUTZ	PROTECCION
29	031.064	1	PROTEZIONE MTZ-100	GUARD	PROTECTION	SCHUTZ	PROTECCION
29	034.210	1	PROTEZIONE MTZ-120	GUARD	PROTECTION	SCHUTZ	PROTECCION
30	031.049	1	TELAIO MTZ-100	FRAME	CHASSIS	RAHMEN	BASTIDOR
30	034.004	1	TELAIO MTZ-120	FRAME	CHASSIS	RAHMEN	BASTIDOR
31	31.02.00.0.08	4	DADO	NUT	ECROU	MUTTER	TUERCA





GRUPPO PALA E RULLO (MTZ 120-135-150-170)
SHOVEL AND ROLLER GROUP (MTZ 120-135-150-170)
GROUPE PELLE ET ROULEAU (MTZ 120-135-150-170)
SCHAUFEL UND WALZEN GRUPPE (MTZ 120-135-150-170)
GRUPO PALA Y RODILLO (MTZ 120-135-150-170)

Tav. 02.0

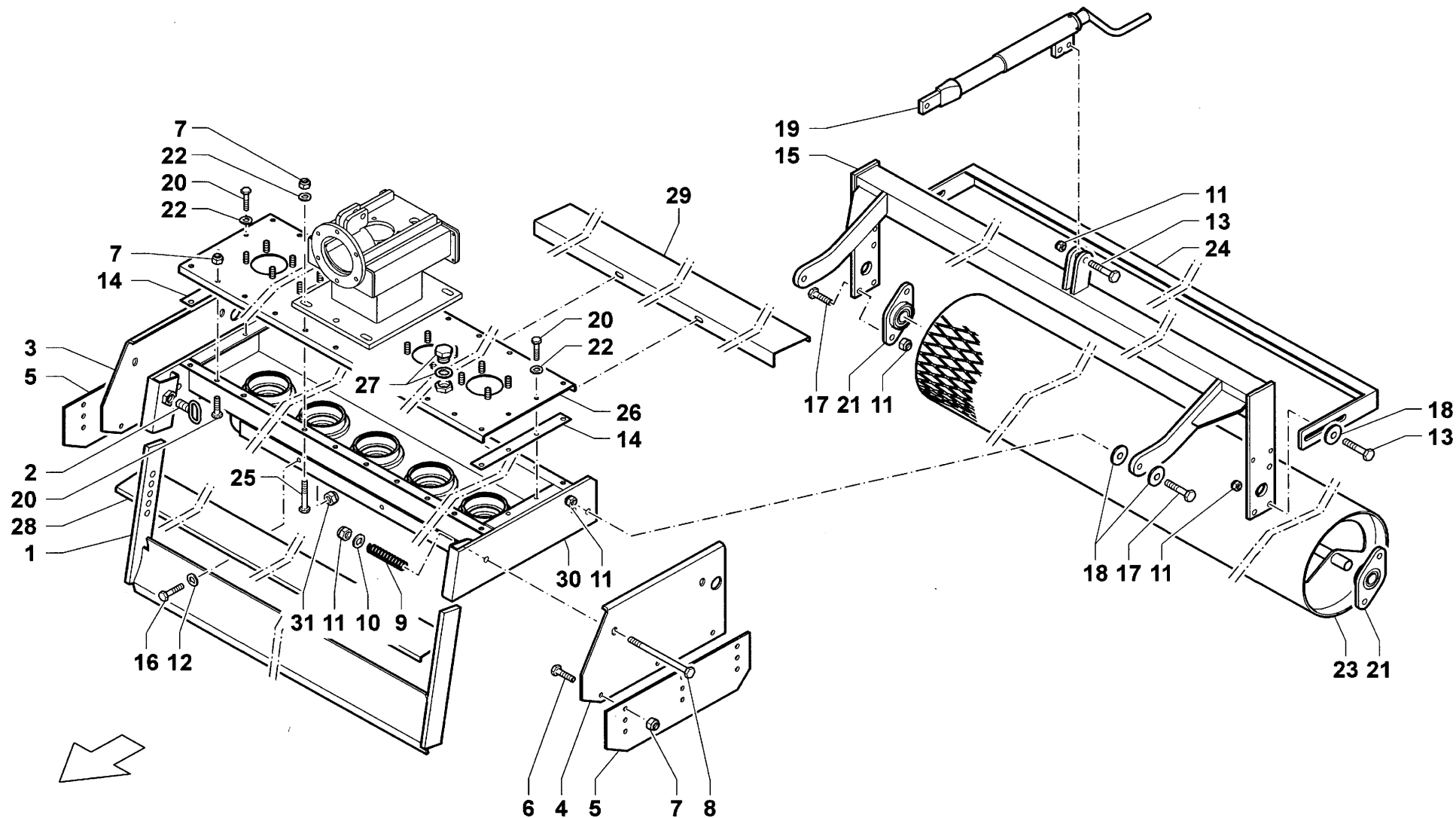

<i>Rif.</i>	<i>CODICE</i>	<i>Qnt</i>	<i>Descrizione</i>	<i>Description</i>	<i>Designation</i>	<i>Benennung</i>	<i>Denominaciones</i>
1	034.038	1	RUSPETTA MTZ-135	LEVELLING BAR	BARRE NIVELEUSE	PLANIERSTANGE	BARRA NIVELADORA
1	034.058	1	RUSPETTA MTZ-150	LEVELLING BAR	BARRE NIVELEUSE	PLANIERSTANGE	BARRA NIVELADORA
1	034.054	1	RUSPETTA MTZ-170	LEVELLING BAR	BARRE NIVELEUSE	PLANIERSTANGE	BARRA NIVELADORA
2	000.001	2	FRULLETTO	THREADED PIN	AXE TARAUDE	GEWINDEBOLZEN	PERNO CON ROSCA
3	000.003	1	FIANCHETTO DX	RIGHT SIDE	COTE DROIT	SEITENWAND RECHTS	CÀRTER DERECHO
4	000.004	1	FIANCHETTO SX	LEFT SIDE	COTE GAUCHE	SEITENWAND LINKS	CÀRTER IZQUIERDO
5	000.005	1	PROLUNGA	EXTENSION	RALLONGE	VERLÄNGERUNG	PROLONGA
6	21.0.0.08016	6	VITE	SCREW	VIS	SCHRAUBE	TORNILLO
7	30.02.00.008	36	DADO AUTOBLOCCANTE	STOP NUT	ECROU DE SURETE	SPERRMUTTER	TUERCA AUTOTRABADORA
8	20.0.0.10100	4	VITE	SCREW	VIS	SCHRAUBE	TORNILLO
9	000.011	4	MOLLA	SPRING	RESSORT	FEDER	RESORTE
10	15.0.0.00.010	4	RONDELLA	WASHER	RONDELLE	SCHEIBE	ARANDELA
11	30.02.00.010	11	DADO AUTOBLOCCANTE	STOP NUT	ECROU DE SURETE	SPERRMUTTER	TUERCA AUTOTRABADORA
12	15.0.0.00.008	8	RONDELLA	WASHER	RONDELLE	SCHEIBE	ARANDELA
13	21.0.0.10045	3	VITE	SCREW	VIS	SCHRAUBE	TORNILLO
14	050.175	2	GUARNIZIONE	SEAL	JOINT	DICHTUNG	GUARNICIÓN
15	034.030	1	SUPPORTO RULLO MTZ-135	SUPPORT	SUPPORT	LAGER	SOPORTE
15	034.059	1	SUPPORTO RULLO MTZ-150	SUPPORT	SUPPORT	LAGER	SOPORTE
15	034.051	1	SUPPORTO RULLO MTZ-170	SUPPORT	SUPPORT	LAGER	SOPORTE
16	21.0.0.08020	8	VITE	SCREW	VIS	SCHRAUBE	TORNILLO
17	21.0.0.10035	6	VITE	SCREW	VIS	SCHRAUBE	TORNILLO
18	15.1.0.00.010	4	RONDELLA	WASHER	RONDELLE	SCHEIBE	ARANDELA
19	034.070/L	1	REGISTRO	ADJUSTER	REGLAGE	REGULATOR	AJUSTE
20	21.0.0.08016	32	VITE	SCREW	VIS	SCHRAUBE	TORNILLO
21	BUCFL204	2	SUPPORTO	SUPPORT	SUPPORT	LAGER	SOPORTE
22	16.00.00.008	12	RONDELLA ELASTICA	SPRING WASHER	RONDELLE ELASTIQUE	FEDERSCHEIBE	ARANDELA ELASTICA
23	034.031	1	RULLO MTZ-135	ROLLER	ROULEAU	WALZE ROLLE	RODILLO
23	034.060	1	RULLO MTZ-150	ROLLER	ROULEAU	WALZE ROLLE	RODILLO
23	034.052	1	RULLO MTZ-170	ROLLER	ROULEAU	WALZE ROLLE	RODILLO
24	034.032	1	PULISCI RULLO MTZ-135	ROLLER CLEANER	NETTOYEUR ROULEAU	WALZENREINIGER	LIMPIADOR RODILLO
24	034.061	1	PULISCI RULLO MTZ-150	ROLLER CLEANER	NETTOYEUR ROULEAU	WALZENREINIGER	LIMPIADOR RODILLO

Tav. 02.0





GRUPPO PALA E RULLO (MTZ 120-135-150-170)
SHOVEL AND ROLLER GROUP (MTZ 120-135-150-170)
GROUPE PELLE ET ROULEAU (MTZ 120-135-150-170)
SCHAUFEL UND WALZEN GRUPPE (MTZ 120-135-150-170)
GRUPO PALA Y RODILLO (MTZ 120-135-150-170)

Tav. 02.0

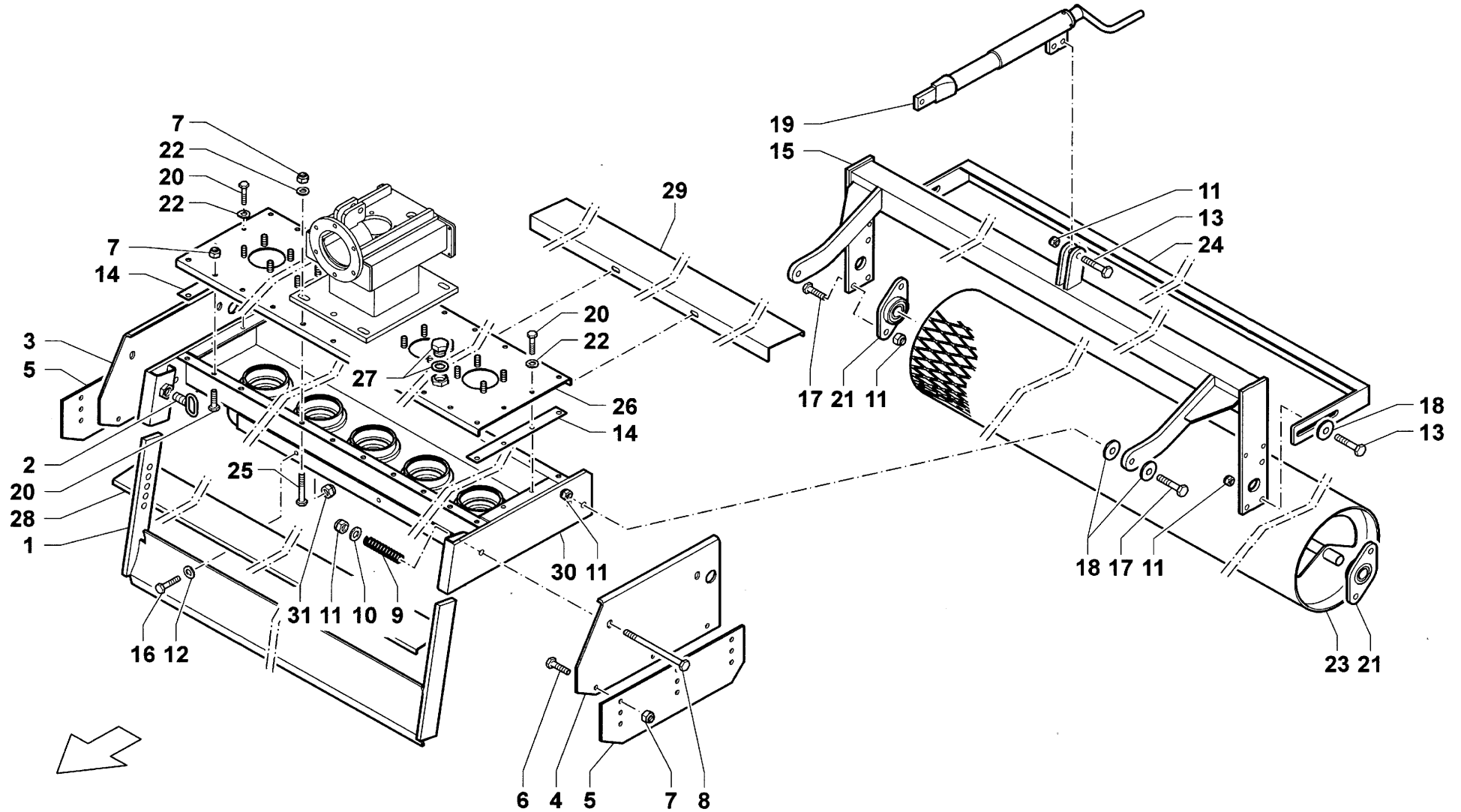

<i>Rif.</i>	<i>CODICE</i>	<i>Qty</i>	<i>Descrizione</i>	<i>Description</i>	<i>Designation</i>	<i>Benennung</i>	<i>Denominaciones</i>
24	034.053	1	PULISCI RULLO MTZ-170	ROLLER CLEANER	NETTOYEUR ROULEAU	WALZENREINIGER	LIMPIADOR RODILLO
25	25.0.0.10030	1	VITE	SCREW	VIS	SCHRAUBE	TORNILLO
26	034.004/C	1	COPERCHIO MTZ-120	COVER	COUVERCLE	DECKEL	TAPA
26	034.045/A	1	COPERCHIO MTZ-135	COVER	COUVERCLE	DECKEL	TAPA
26	034.059/A	1	COPERCHIO MTZ-150	COVER	COUVERCLE	DECKEL	TAPA
26	034.049/A	1	COPERCHIO MTZ-170	COVER	COUVERCLE	DECKEL	TAPA
27	005.001	1	TAPPO	PLUG	BOUCHON	STOPFEN	TAPÓN
28	034.213	1	PROTEZIONE MTZ-135	GUARD	PROTECTION	SCHUTZ	PROTECCION
28	034.215	1	PROTEZIONE MTZ-150	GUARD	PROTECTION	SCHUTZ	PROTECCION
28	034.217	1	PROTEZIONE MTZ-170	GUARD	PROTECTION	SCHUTZ	PROTECCION
29	034.212	1	PROTEZIONE MTZ-135	GUARD	PROTECTION	SCHUTZ	PROTECCION
29	034.214	1	PROTEZIONE MTZ-150	GUARD	PROTECTION	SCHUTZ	PROTECCION
29	034.216	1	PROTEZIONE MTZ-170	GUARD	PROTECTION	SCHUTZ	PROTECCION
30	034.004/H	1	TELAIO MTZ-120	FRAME	CHASSIS	RAHMEN	BASTIDOR
30	034.045	1	TELAIO MTZ-135	FRAME	CHASSIS	RAHMEN	BASTIDOR
30	034.057	1	TELAIO MTZ-150	FRAME	CHASSIS	RAHMEN	BASTIDOR
30	034.049	1	TELAIO MTZ-170	FRAME	CHASSIS	RAHMEN	BASTIDOR
31	31.02.00.0.08	4	DADO	NUT	ECROU	MUTTER	TUERCA





TELAIO E ACCESSORI
FRAME AND ACCESSORIES
CHASSIS ET ACCESSOIRES
RAHMEN UND ZEBÖHR
BASTIDOR Y ACCESORIOS

Tav. 03.0

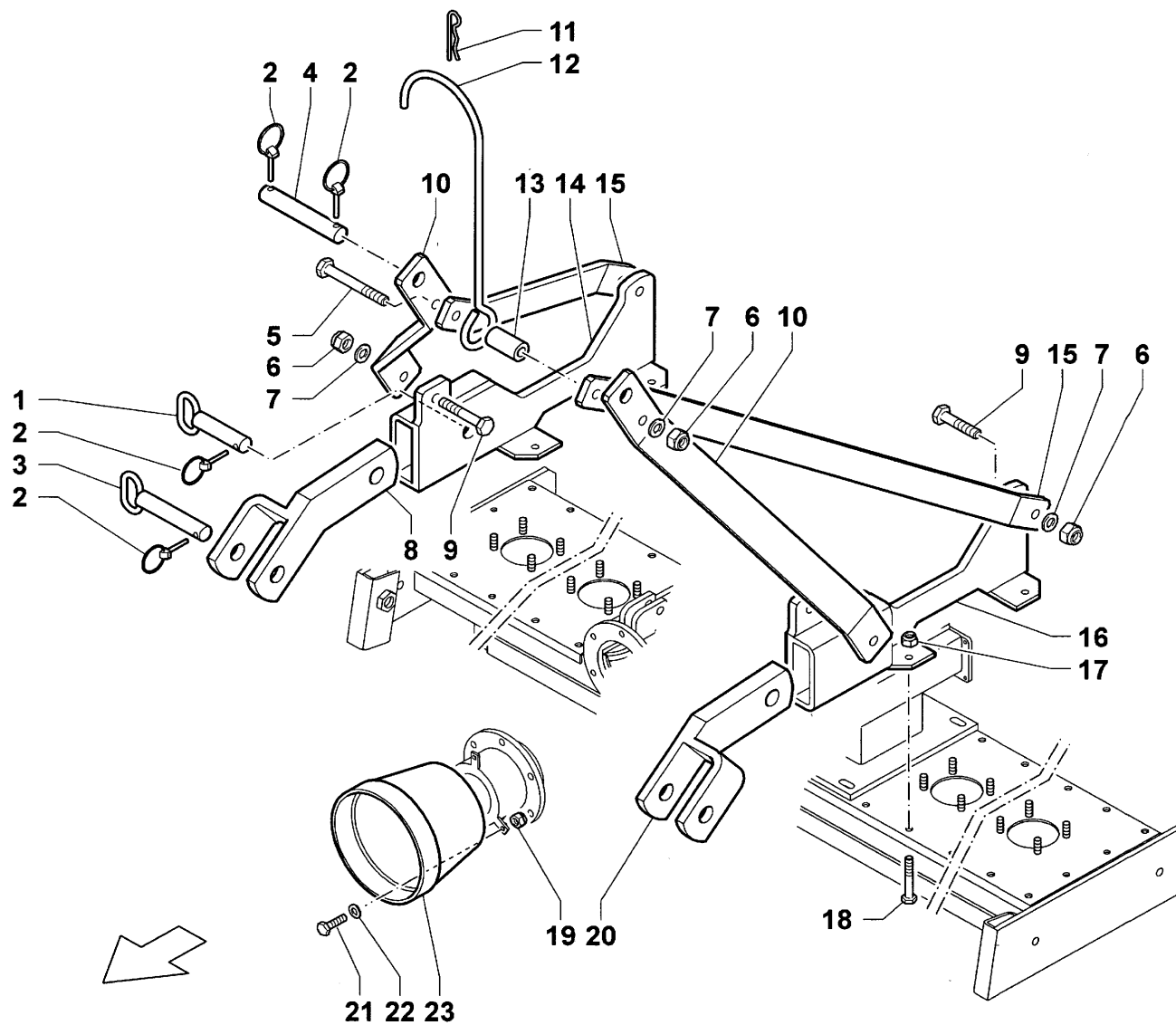

<i>Rif.</i>	<i>CODICE</i>	<i>Qty</i>	<i>Descrizione</i>	<i>Description</i>	<i>Designation</i>	<i>Benennung</i>	<i>Denominaciones</i>
1	000.056	2	PERNO CORTO	THIN PIN	TOURILLON COURT	NIEDRIGER BOLZEN	PERNO BAJO
2	050.159	4	SPINOTTO A SCATTO	RELEASE PIN	BROCHE DE SÛRETE	SPRINGSTECKER	PASADOR DISPARO
3	000.016	2	PERNO LUNGO	HIGHT PIN	TOURILLON LONG	HOHER BOLZEN	PERNO ALTO
4	000.017	1	PERNO	PIN	PIVOT	BOLZEN	PERNO
5	20.0.0.12090	1	VITE	SCREW	VIS	SCHRAUBE	TORNILLO
6	30.02.00.012	5	DADO AUTOBLOCCANTE	STOP NUT	ECROU DE SURETE	SPERRMUTTER	TUERCA AUTOTRABADORA
7	15.0.0.00.012	5	RONDELLA	WASHER	RONDELLE	SCHEIBE	ARANDELA
8	000.014	1	BRACCIO DX	ARM	BRAS	ARM	BRAZO
9	20.0.0.12040	4	VITE	SCREW	VIS	SCHRAUBE	TORNILLO
10	034.008	2	LAMA ANTERIORE	FRONT TIE-ROD	TIRANT AVANT	VORDERE ZUGSTANGE	TIRANTE ANTERIOR
11	050.005	1	COPIGLIA A "R"	COTTER PIN	GOUPILLE	SPLINT	CLAVIJA
12	034.019	1	GANCIO LUNGO 100-120	HOOK	CROCHET	HAKEN	GANCHO
12	034.045	1	GANCIO CORTO 120 -135-150-170	HOOK	CROCHET	HAKEN	GANCHO
13	034.012	1	DISTANZIALE	SPACER	ENTRETOISE	ABSTANDSTUECK	SEPARADOR
14	034.022.DX	1	SUPPORTO ATT. TRATTORE	TRACTOR RIGHT	SUPPORT RACCORD	ANSCHLUBHALTERUNG	SOPORTE ENGANCHE
				CONNECTION SUPPORT	TRACTEUR GAUCHE	TRAKTOR LINKS	TRACTOR IZQUIERDO
15	034.009	2	LAMA POSTERIORE	REAR TIE-ROD	TIRANT ARRIERE	HINTERE ZUGSTANGE	TIRANTE POSTERIOR
16	034.022.SX	1	SUPPORTO ATT. TRATTORE	TRACTOR RIGHT	SUPPORT RACCORD	ANSCHLUBHALTERUNG	SOPORTE ENGANCHE
				CONNECTION SUPPORT	TRACTEUR GAUCHE	TRAKTOR LINKS	TRACTOR IZQUIERDO
17	30.02.00.010	8	DADO AUTOBLOCCANTE	STOP NUT	ECROU DE SURETE	SPERRMUTTER	TUERCA AUTOTRABADORA
18	21.0.0.10030	8	VITE	SCREW	VIS	SCHRAUBE	TORNILLO
19	30.01.00.008	3	DADO	NUT	ECROU	MUTTER	TUERCA
20	000.015	1	BRACCIO SX	ARM	BRAS	ARM	BRAZO
21	21.0.0.08016	3	VITE	SCREW	VIS	SCHRAUBE	TORNILLO
22	15.0.0.00.008	3	RONDELLA	WASHER	RONDELLE	SCHEIBE	ARANDELA
23	050.052	1	CUFFIA CARDANO	CARDAN JOINT COVER	PROTECTION JOINT DE CARDAN	SCHUTZHAUBE KARDANGELENK	PROTECCIÓN JUNTA CARDAN
24	050.054	1	ALBERO CARDANICO	CARDAN SHAFT	ARBRE CARDAN	KARDANWELLE	ARBOL CARDANICO

Tav. 03.0





TRASMISSIONE (MTZ 100-120)
TRANSMISSION (MTZ 100-120)
TRANSMISSION (MTZ 100-120)
TRANSMISSION (MTZ 100-120)
TRANSMISSION (MTZ 100-120)

Tav. 04.0

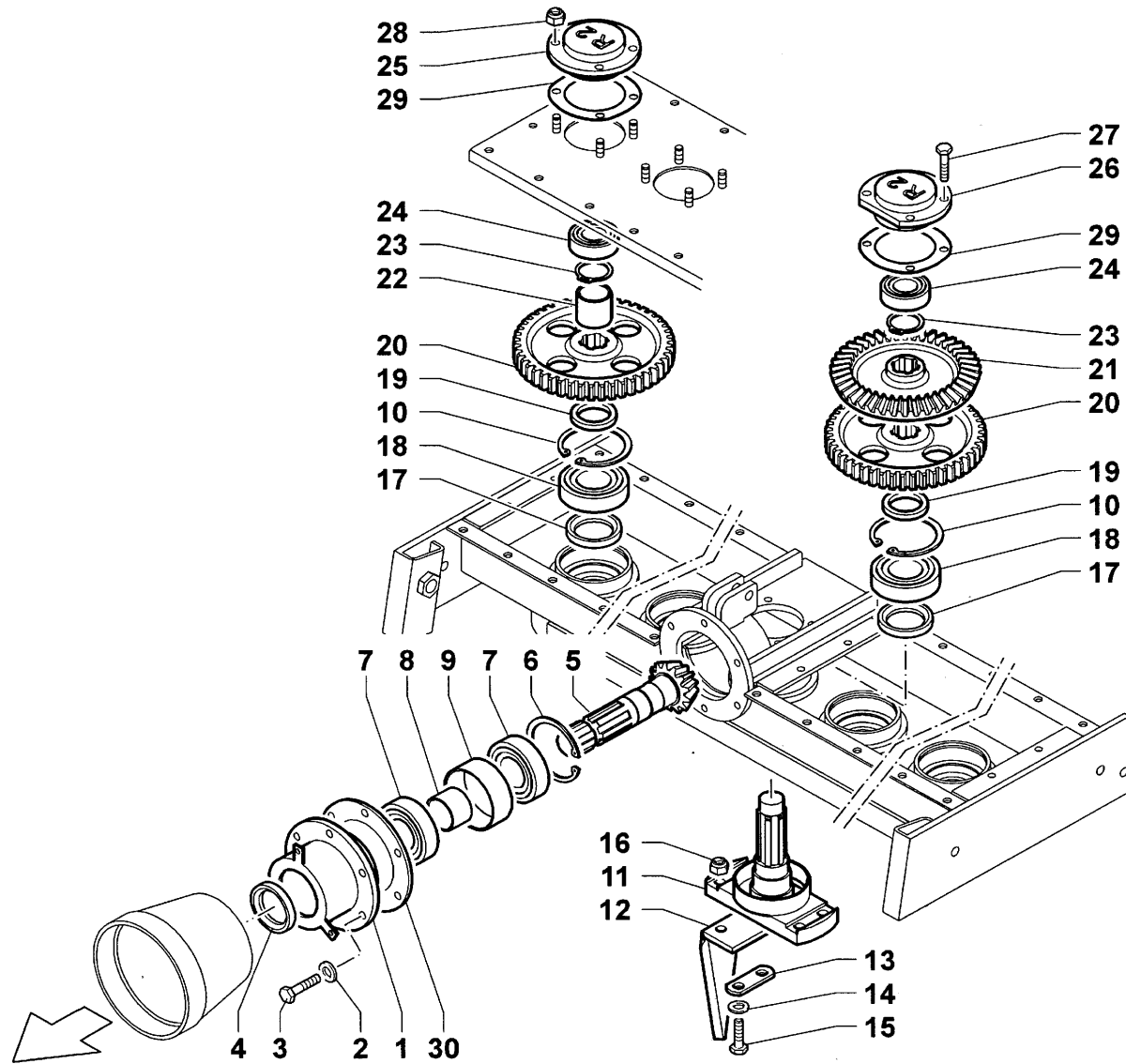

<i>Rif.</i>	<i>CODICE</i>	<i>Qty</i>	<i>Descrizione</i>	<i>Description</i>	<i>Designation</i>	<i>Benennung</i>	<i>Denominaciones</i>
1	034.003	1	MOZZO	HUB	MOYEU	NABE	CUBO
2	16.00.00.008	6	RONDELLA ELASTICA	SPRING WASHER	RONDELLE ELASTIQUE	FEDERSCHEIBE	ARANDELA ELASTICA
3	21.0.0.08025	6	VITE	SCREW	VIS	SCHRAUBE	TORNILLO
4	D30627	1	PARAOILIO	OIL SEAL	PARE-HUILE	OLEABDICHTUNG	CHAPA RETENC. ACEITE
5	034.002	1	PIGNONE	PINION	PIGNON	RITZEL	PINON
6	18.00.00.072	1	SEEGER	RING	BAGUE	RING	ANILLO
7	A6207	2	CUSCINETTO	BEARING	PALIER	LAGERSCHALE	COJINETE
8	031.045	1	DISTANZIALE	SPACER	ENTRETOISE	ABSTANDSTUECK	SEPARADOR
9	031.046	1	DISTANZIALE	SPACER	ENTRETOISE	ABSTANDSTUECK	SEPARADOR
10	18.00.00.072	5	SEEGER	RING	BAGUE	RING	ANILLO
11	031.033	5	FORCELLA	FORK	FOURCHE	GABEL	HORQUILLA
12	000.010	10	ZAPPETTA	HOE	HOUE	ZINKEN	AZADA
13	000.002	10	PIASTRINA	PLATE	PLAQUETTE	PLÄTTCHEN	PLACA
14	16.00.00.010	20	RONDELLA ELASTICA	SPRING WASHER	RONDELLE ELASTIQUE	FEDERSCHEIBE	ARANDELA ELASTICA
15	20.0.1.10045	20	VITE	SCREW	VIS	SCHRAUBE	TORNILLO
16	30.02.00.010	20	DADO AUTOBLOCCANTE	STOP NUT	ECROU DE SURETE	SPERRMUTTER	TUERCA AUTOTRABADORA
17	D405810TGP	5	PARAOILIO	OIL SEAL	PARE-HUILE	OLEABDICHTUNG	CHAPA RETENC. ACEITE
18	A620711	5	CUSCINETTO	BEARING	PALIER	LAGERSCHALE	COJINETE
19	031.041	5	DISTANZIALE	SPACER	ENTRETOISE	ABSTANDSTUECK	SEPARADOR
20	034.197	5	INGRANAGGIO	GEAR	ENGRENAGE	ZAHNRADGETRIEBE	ENGRANAJE
21	034.001	1	CORONA	RING GEAR	COURONNE	KRANZ	CORONA
22	000.012	4	DISTANZIALE	SPACER	ENTRETOISE	ABSTANDSTUECK	SEPARADOR
23	18.01.00.030	5	SEEGER	RING	BAGUE	RING	ANILLO
24	A6205	5	CUSCINETTO	BEARING	PALIER	LAGERSCHALE	COJINETE
25	031.010	4	COPERCHIETTO LATERALE	SIDE COVER	COUVERCLE LATÉRAL	KLEINER SEITL. DECKEL	TAPA LATERAL
26	031.009	1	COPERCHIETTO CENTRALE	CENTRAL COVER	COUVERCLE CENTRALE	KLEINER ZENTRALER DECKEL	TAPA CENTRAL
27	21.0.0.08016	4	VITE	SCREW	VIS	SCHRAUBE	TORNILLO
28	30.02.00.008	16	DADO AUTOBLOCCANTE	STOP NUT	ECROU DE SURETE	SPERRMUTTER	TUERCA AUTOTRABADORA
29	000.032	5	GUARNIZIONE	SEAL	JOINT	DICHTUNG	GUARNICIÓN
30	000.045	1	GUARNIZIONE	SEAL	JOINT	DICHTUNG	GUARNICIÓN

Tav. 04.0





TRASMISSIONE (MTZ 120-135-150-170)
TRANSMISSION (MTZ 120-135-150-170)
TRANSMISSION (MTZ 120-135-150-170)
TRANSMISSION (MTZ 120-135-150-170)
TRANSMISSION (MTZ 120-135-150-170)

Tav. 05.0

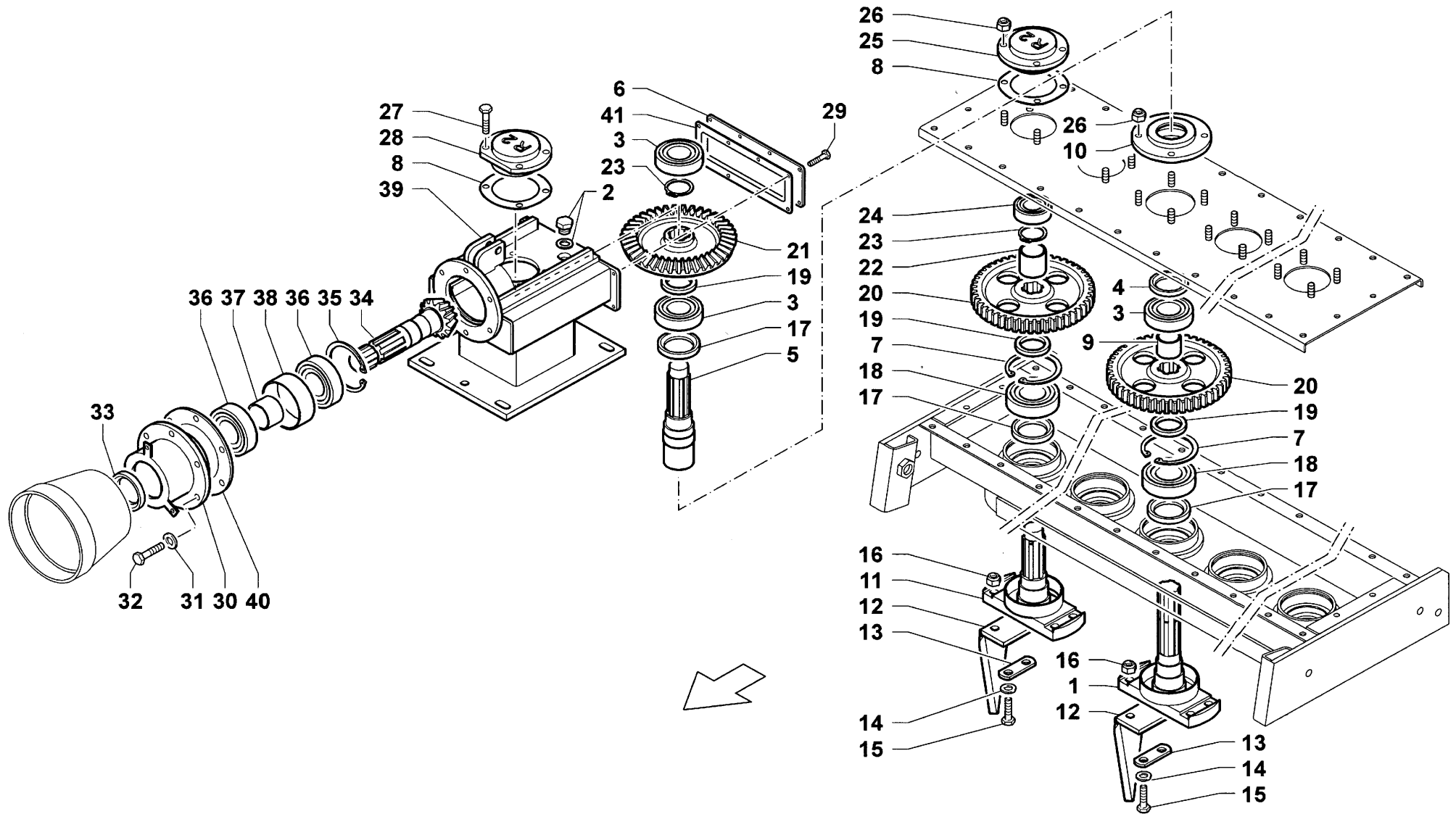

<i>Rif.</i>	<i>CODICE</i>	<i>Qty</i>	<i>Descrizione</i>	<i>Description</i>	<i>Designation</i>	<i>Benennung</i>	<i>Denominaciones</i>
1	034.047	1	FORCELLA (MTZ 135-120)	FORK	FOURCHE	GABEL	HORQUILLA
1	034.207	1	FORCELLA (MTZ 150-170)	FORK	FOURCHE	GABEL	HORQUILLA
2	005.001	1	TAPPO	PLUG	BOUCHON	STOPFEN	TAPÓN
3	A6206	2	CUSCINETTO (MTZ 135-120)	BEARING	PALIER	LAGERSCHALE	COJINETE
3	A6207	2	CUSCINETTO (MTZ 150-170)	BEARING	PALIER	LAGERSCHALE	COJINETE
4	D40527	1	PARAOLIO (MTZ 135-120)	OIL SEAL	PARE-HUILE	OLEABDICHTUNG	CHAPA RETENC. ACEITE
4	D45567	1	PARAOLIO (MTZ 150-170)	OIL SEAL	PARE-HUILE	OLEABDICHTUNG	CHAPA RETENC. ACEITE
5	043.040	1	ALBERO SCANALATO (MTZ 135)	SPLINE SHAFT	ARBRE CANELÉ	GENUTETE WELLE	ARBOR ACANALADO
5	034.208	1	ALBERO SCANALATO (MTZ 150-170)	SPLINE SHAFT	ARBRE CANELÉ	GENUTETE WELLE	ARBOR ACANALADO
6	034.043	1	COPERCHIO POSTERIORE	BACK COVER	COUVERCLE POSTÉRIEURE	HINT. ABDECKUNG	TAPA POSTERIOR
7	18.00.00.072	7	SEEGER	RING	BAGUE	RING	ANILLO
8	000.032	7	GUARNIZIONE	SEAL	JOINT	DICHTUNG	GUARNICIÓN
9	034.042	1	DISTANZIALE (MTZ 135-120)	SPACER	ENTRETOISE	ABSTANDSTUECK	SEPARADOR
9	034.206	1	DISTANZIALE (MTZ 150-170)	SPACER	ENTRETOISE	ABSTANDSTUECK	SEPARADOR
10	034.041	1	COPERCHIETTO (MTZ 135)	COVER	COUVERCLE	KLEINER DECKEL	TAPA
10	034.041/A	1	COPERCHIETTO (MTZ 150-170)	COVER	COUVERCLE	KLEINER DECKEL	TAPA
11	031.033	6	FORCELLA	FORK	FOURCHE	GABEL	HORQUILLA
12	000.010	14	ZAPPETTA	HOE	HOUE	ZINKEN	AZADA
13	000.002	14	PIASTRINA	PLATE	PLAQUETTE	PLÄTTCHEN	PLACA
14	16.00.00.010	28	RONDELLA ELASTICA	SPRING WASHER	RONDELLE ELASTIQUE	FEDERSCHEIBE	ARANDELA ELASTICA
15	20.0.1.10045	28	VITE	SCREW	VIS	SCHRAUBE	TORNILLO
16	30.02.00.010	28	DADO AUTOBLOCCANTE	STOP NUT	ECROU DE SURETE	SPERRMUTTER	TUERCA AUTOTRABADORA
17	D405810T4P	8	PARAOLIO	OIL SEAL	PARE-HUILE	OLEABDICHTUNG	CHAPA RETENC. ACEITE
18	A6207	7	CUSCINETTO	BEARING	PALIER	LAGERSCHALE	COJINETE
19	031.041	8	DISTANZIALE (MTZ 120-135)	SPACER	ENTRETOISE	ABSTANDSTUECK	SEPARADOR
19	034.218	8	DISTANZIALE (MTZ 150-170)	SPACER	ENTRETOISE	ABSTANDSTUECK	SEPARADOR
20	031.005	7	INGRANAGGIO (MTZ 120-135)	GEAR	ENGRENAGE	ZAHNRADGETRIEBE	ENGRANAJE
20	034.197	7	INGRANAGGIO (MTZ 150-170)	GEAR	ENGRENAGE	ZAHNRADGETRIEBE	ENGRANAJE
21	034.001	1	CORONA	RING GEAR	COURONNE	KRANZ	CORONA
22	000.012	5	DISTANZIALE	SPACER	ENTRETOISE	ABSTANDSTUECK	SEPARADOR
23	18.01.00.030	8	SEEGER	RING	BAGUE	RING	ANILLO

Tav. 05.0





TRASMISSIONE (MTZ 120-135-150-170)
TRANSMISSION (MTZ 120-135-150-170)
TRANSMISSION (MTZ 120-135-150-170)
TRANSMISSION (MTZ 120-135-150-170)
TRANSMISSION (MTZ 120-135-150-170)

Tav. 05.0

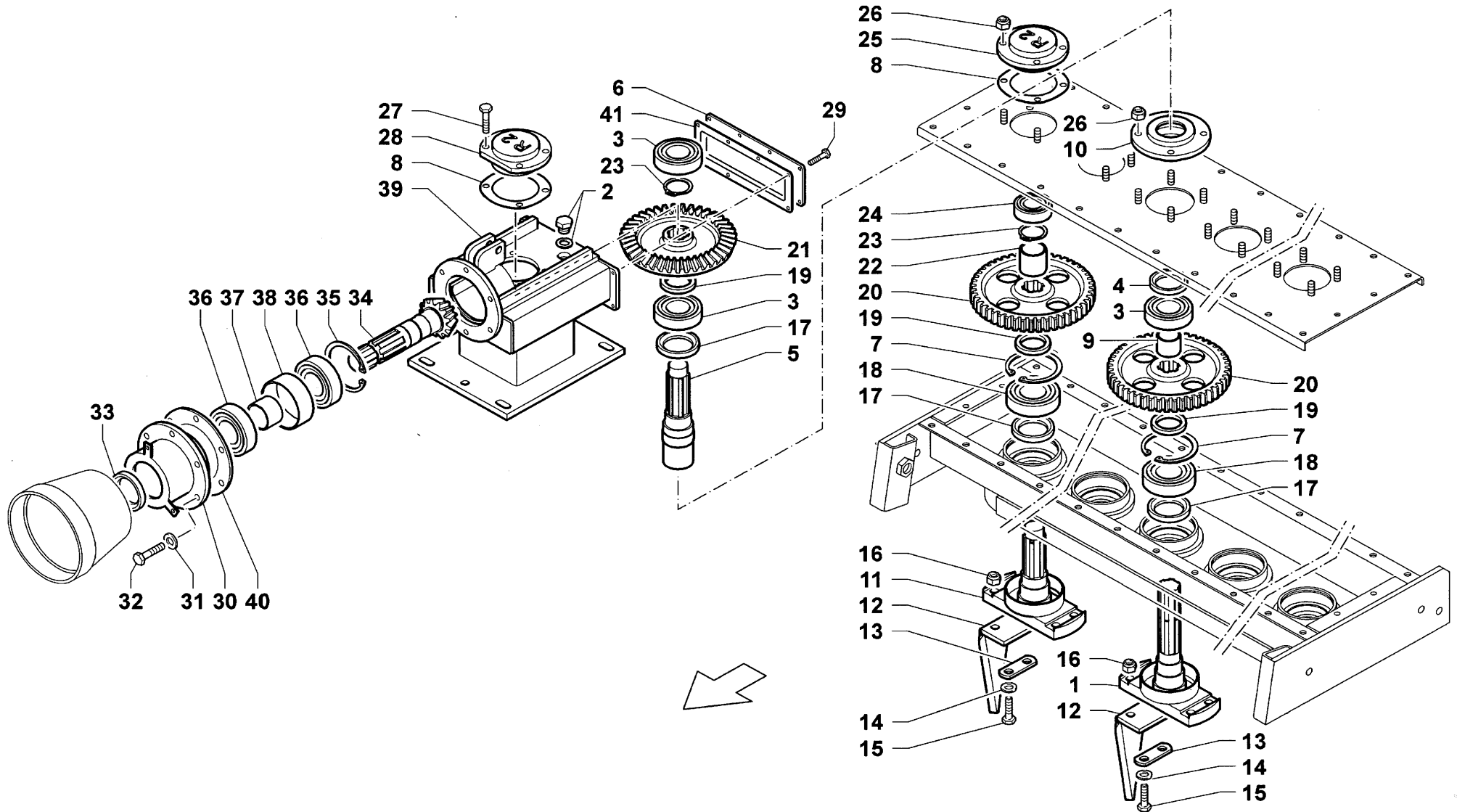

<i>Rif.</i>	<i>CODICE</i>	<i>Qnt</i>	<i>Descrizione</i>	<i>Description</i>	<i>Designation</i>	<i>Benennung</i>	<i>Denominaciones</i>
24	A6205	6	CUSCINETTO	BEARING	PALIER	LAGERSCHALE	COJINETE
25	031.010	6	COPERCHIETTO LATERALE	SIDE COVER	COUVERCLE LATERAL	KLEINER SEITL. DECKEL	TAPA LATERAL
26	30.02.00.008	28	DADO AUTOBLOCCANTE	STOP NUT	ECROU DE SURETE	SPERRMUTTER	TUERCA AUTOTRABADORA
27	21.0.0.08016	4	VITE	SCREW	VIS	SCHRAUBE	TORNILLO
28	037.031	1	COPERCHIETTO CENTRALE	CENTRAL COVER	COUVERCLE CENTRALE	KLEINER ZENTRALER DECKEL	TAPA CENTRAL
29	21.0.0.05016	8	VITE	SCREW	VIS	SCHRAUBE	TORNILLO
30	034,003	1	MOZZO	HUB	MOYEU	NABE	CUBO
31	16.00.00.008	6	RONDELLA ELASTICA	SPRING WASHER	RONDELLE ELASTIQUE	FEDERSCHEIBE	ARANDELA ELASTICA
32	21.0.0.08025	6	VITE	SCREW	VIS	SCHRAUBE	TORNILLO
33	D30627	1	PARAOLIO	OIL SEAL	PARE-HUILE	OLEABDICHTUNG	CHAPA RETENC. ACEITE
34	034.002	1	PIGNONE	PINION	PIGNON	RITZEL	PINON
35	18.00.00.072	1	SEEGER	RING	BAGUE	RING	ANILLO
36	A6207	2	CUSCINETTO	BEARING	PALIER	LAGERSCHALE	COJINETE
37	031.045	1	DISTANZIALE	SPACER	ENTRETOISE	ABSTANDSTUECK	SEPARADOR
38	031.046	1	DISTANZIALE	SPACER	ENTRETOISE	ABSTANDSTUECK	SEPARADOR
39	034.046	1	SCATOLA RIDUTTORE	REDUCTION CASING	BOITE REDUCTEUR	UNTERSETZUNGSGETRIEBEKASTEN	CAJA DE REDUCTOR
40	000.045	1	GUARNIZIONE	SEAL	JOINT	DICHTUNG	GUARNICIÓN
41	000.041	1	GUARNIZIONE	SEAL	JOINT	DICHTUNG	GUARNICIÓN





TRASMISSIONE IDRAULICA (MTZHI)
HYDRAULIC TRANSMISSION (MTZHI)
TRANSMISSION HIDRAULIQUE (MTZHI)
HYDRAULIKANTRIEB (MTZHI)
TRANSMISIÓN HIDRÁULICA (MTZHI)

Tav. 06.0

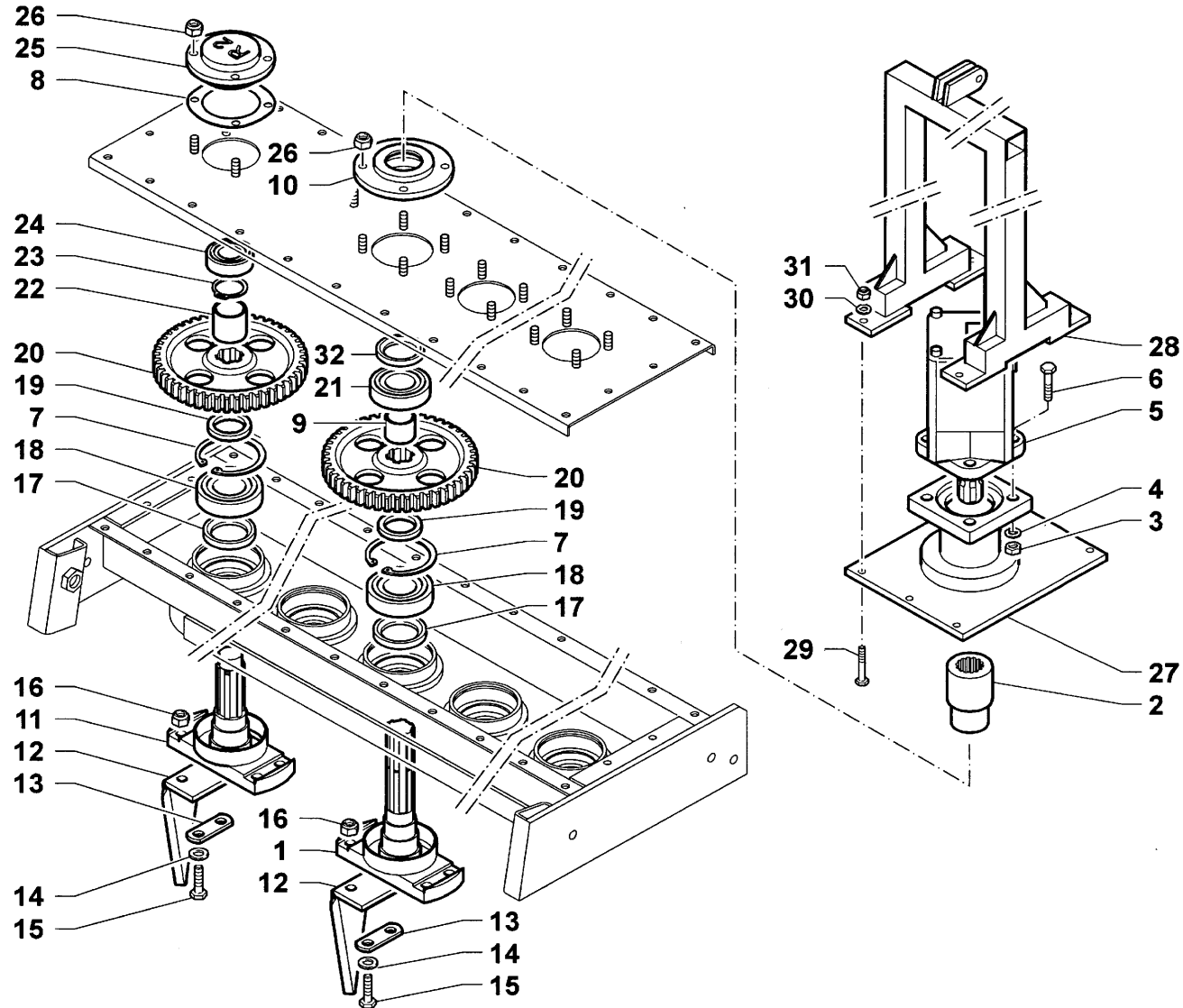

<i>Rif.</i>	<i>CODICE</i>	<i>Qnt</i>	<i>Descrizione</i>	<i>Description</i>	<i>Designation</i>	<i>Benennung</i>	<i>Denominaciones</i>
1	034.047	1	FORCELLA (MTZ 135-120)	FORK	FOURCHE	GABEL	HORQUILLA
1	034.207	1	FORCELLA (MTZ 150-170)	FORK	FOURCHE	GABEL	HORQUILLA
2	015.010	1	MANICOTTO TRASM (MTZ 135)	TRANSMISSION SLEEVE	MANCHON TRANSMISSION	TRANSMISSIONSROHR	MANGUITO TRANSMISIÓN
2	015.012/A	1	MANICOTTO TRASM (MTZ 150-170)	TRANSMISSION SLEEVE	MANCHON TRANSMISSION	TRANSMISSIONSROHR	MANGUITO TRANSMISIÓN
3	30.02.00.012	4	DADO AUTOBLOCCANTE	STOP NUT	ECROU DE SURETE	SPERRMUTTER	TUERCA AUTOTRABADORA
4	15.0.0.00.012	4	RONDELLA	WASHER	RONDELLE	SCHEIBE	ARANDELA
5	050.045	1	MOTORE IDRAULICO	HYDRAULIC MOTOR	MOTEUR HYDRAULIQUE	HYDRAULIKMOTOR	MOTOR HIDRAULICO
6	22.0.1.12055	4	VITE	SCREW	VIS	SCHRAUBE	TORNILLO
7	18.00.00.072	5	SEEGER	RING	BAGUE	RING	ANILLO
8	000.032	4	GUARNIZIONE	SEAL	JOINT	DICHTUNG	GUARNICIÓN
9	034.042	1	DISTANZIALE (MTZ 135-120)	SPACER	ENTRETOISE	ABSTANDSTUECK	SEPARADOR
9	034.206	1	DISTANZIALE (MTZ 150-170)	SPACER	ENTRETOISE	ABSTANDSTUECK	SEPARADOR
10	034.041	1	COPERCHIETTO CENTRALE	CENTRAL COVER	COUVERCLE CENTRALE	KLEINER ZENTRALER DECKEL	TAPA CENTRAL
11	031.033	4	FORCELLA	FORK	FOURCHE	GABEL	HORQUILLA
12	000.010	10	ZAPPETTA	HOE	HOUE	ZINKEN	AZADA
13	000.002	10	PIASTRINA	PLATE	PLAQUETTE	PLÄTTCHEN	PLACA
14	16.00.00.010	20	RONDELLA ELASTICA	SPRING WASHER	RONDELLE ELASTIQUE	FEDERSCHEIBE	ARANDELA ELASTICA
15	20.0.1.10045	20	VITE	SCREW	VIS	SCHRAUBE	TORNILLO
16	30.02.00.010	20	DADO AUTOBLOCCANTE	STOP NUT	ECROU DE SURETE	SPERRMUTTER	TUERCA AUTOTRABADORA
17	D405810TGP	8	PARAOILIO	OIL SEAL	PARE-HUILE	OLEABDICHTUNG	CHAPA RETENC. ACEITE
18	A6207	7	CUSCINETTO	BEARING	PALIER	LAGERSCHALE	COJINETE
19	031.041	8	DISTANZIALE (MTZ 120-135)	SPACER	ENTRETOISE	ABSTANDSTUECK	SEPARADOR
19	034.218	8	DISTANZIALE (MTZ 150-170)	SPACER	ENTRETOISE	ABSTANDSTUECK	SEPARADOR
20	031.005	7	INGRANAGGIO (MTZ 120-135)	GEAR	ENGRENAGE	ZAHNRADGETRIEBE	ENGRANAJE
20	034.197	7	INGRANAGGIO (MTZ 150-170)	GEAR	ENGRENAGE	ZAHNRADGETRIEBE	ENGRANAJE
21	A6206	2	CUSCINETTO (MTZ 135-120)	BEARING	PALIER	LAGERSCHALE	COJINETE
21	A6207	2	CUSCINETTO (MTZ 150-170)	BEARING	PALIER	LAGERSCHALE	COJINETE
22	000.012	4	DISTANZIALE	SPACER	ENTRETOISE	ABSTANDSTUECK	SEPARADOR
23	18.01.00.030	5	SEEGER	RING	BAGUE	RING	ANILLO
24	A6205	4	CUSCINETTO	BEARING	PALIER	LAGERSCHALE	COJINETE
25	031.010	4	COPERCHIETTO LATERALE	SIDE COVER	COUVERCLE LATERAL	KLEINER SEITL. DECKEL	TAPA LATERAL

Tav. 06.0





TRASMISSIONE IDRAULICA (MTZHI)
HYDRAULIC TRANSMISSION (MTZHI)
TRANSMISSION HIDRAULIQUE (MTZHI)
HYDRAULIKANTRIEB (MTZHI)
TRANSMISIÓN HIDRÁULICA (MTZHI)

Tav. 06.0

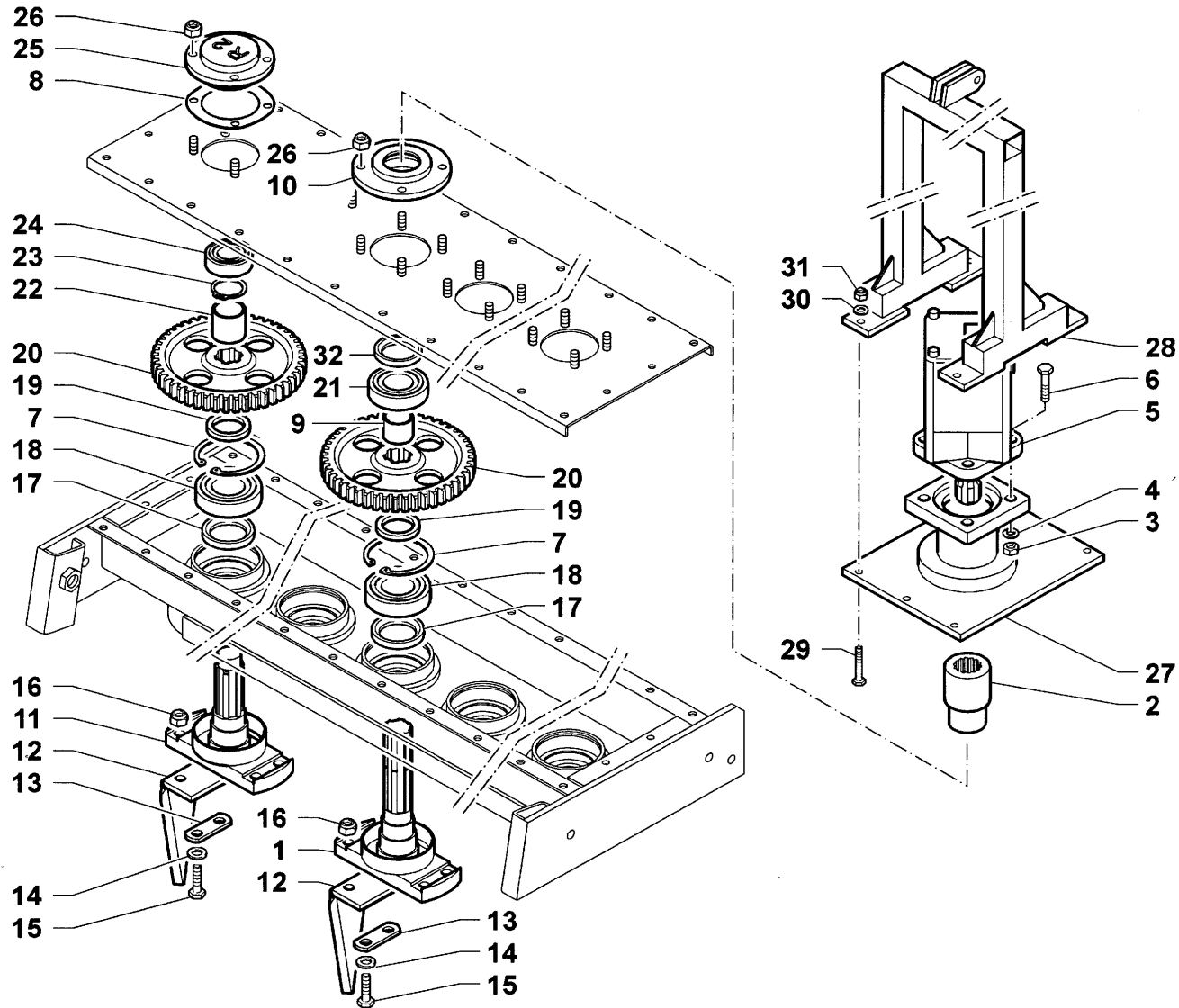



KIT RULLO A GABBIA
CAGE ROLLER KIT
KIT ROULEAU A CAGE
KAFIGWALZENKIT
KIT RODILLO A JAULA

Tav. 07.0

OPTIONAL

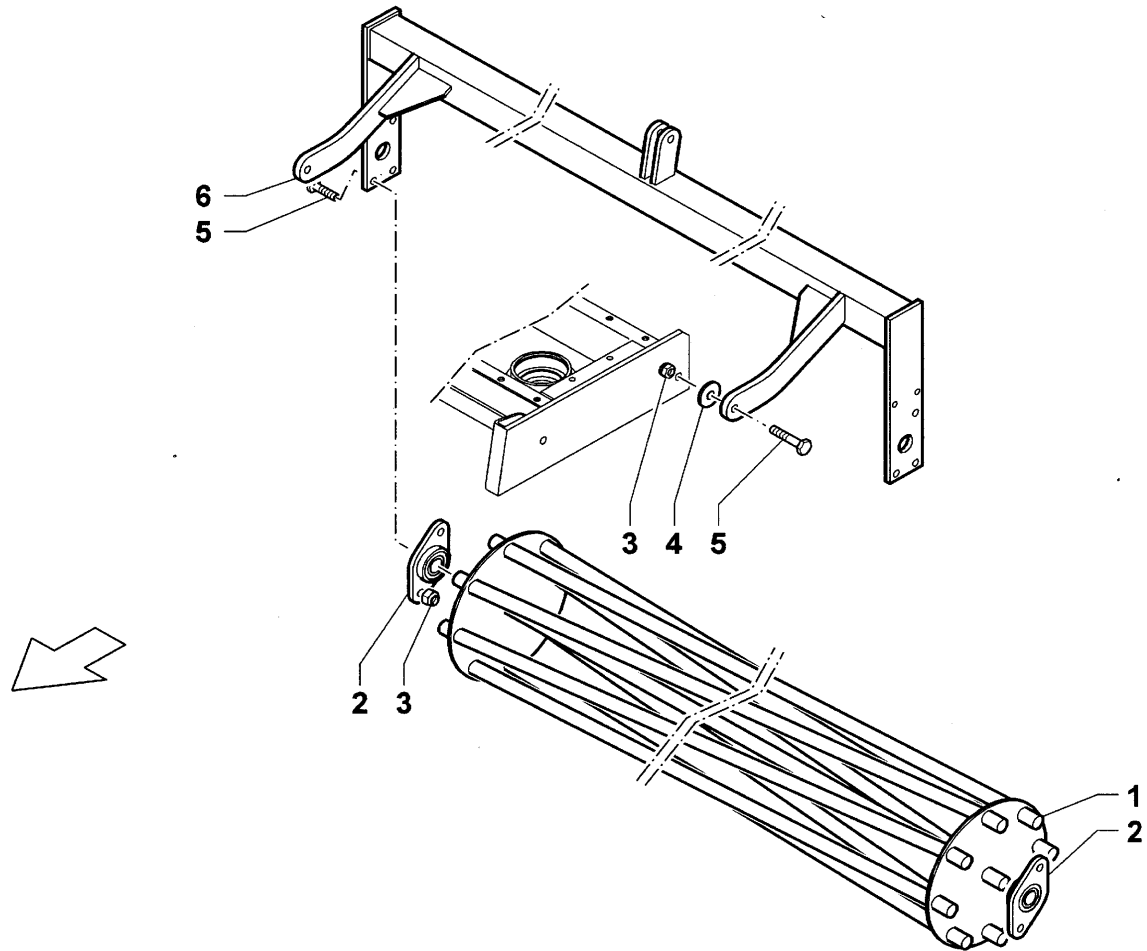

Rif.	CODICE	Qnt	Descrizione	Description	Designation	Benennung	Denominaciones
1	031.014	1	RULLO MTZ-100	ROLLER	ROULEAU	WALZE ROLLE	RODILLO
1	034.029	1	RULLO MTZ-120	ROLLER	ROULEAU	WALZE ROLLE	RODILLO
1	034.056	1	RULLO MTZ-135	ROLLER	ROULEAU	WALZE ROLLE	RODILLO
1	034.076	1	RULLO MTZ-150	ROLLER	ROULEAU	WALZE ROLLE	RODILLO
1	034.198	1	RULLO MTZ-170	ROLLER	ROULEAU	WALZE ROLLE	RODILLO
2	BUCFL204	2	SUPPORTO	SUPPORT	SUPPORT	LAGER	SOPORTE
3	30.02.00.010	6	DADO AUTOBLOCCANTE	STOP NUT	ECROU DE SURETE	SPERRMUTTER	TUERCA AUTOTRABADORA
4	15.1.0.00.010	2	RONDELLA	WASHER	RONDELLE	SCHEIBE	ARANDELA
5	21.0.0.10035	6	VITE	SCREW	VIS	SCHRAUBE	TORNILLO
6	031.011	1	SUPPORTO RULLO MTZ-100	SUPPORT	SUPPORT	LAGER	SOPORTE
6	034.027	1	SUPPORTO RULLO MTZ-120	SUPPORT	SUPPORT	LAGER	SOPORTE
6	034.028	1	SUPPORTO RULLO MTZ-135	SUPPORT	SUPPORT	LAGER	SOPORTE
6	034.077	1	SUPPORTO RULLO MTZ-150	SUPPORT	SUPPORT	LAGER	SOPORTE
6	034.199	1	SUPPORTO RULLO MTZ-170	SUPPORT	SUPPORT	LAGER	SOPORTE





KIT RULLO PIENO
PLAIN ROLLER KIT
KIT ROULEAU PLEIN
VOLLWALZENKIT
KIT RODILLO LLANO

Tav. 08.0

OPTIONAL

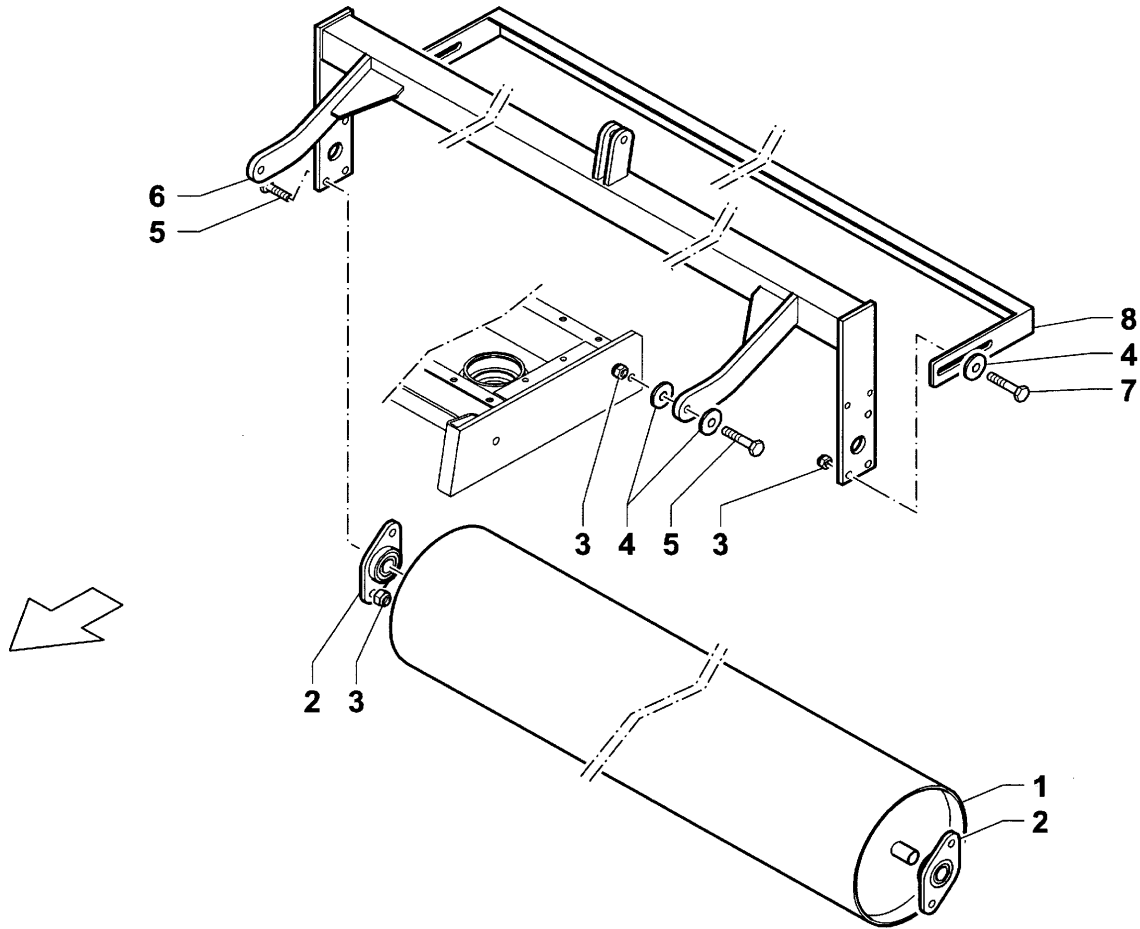

<i>Rif.</i>	<i>CODICE</i>	<i>Qty</i>	<i>Descrizione</i>	<i>Description</i>	<i>Designation</i>	<i>Benennung</i>	<i>Denominaciones</i>
1	031.039/P	1	RULLO MTZ-100	ROLLER	ROULEAU	WALZE ROLLE	RODILLO
1	034.007/P	1	RULLO MTZ-120	ROLLER	ROULEAU	WALZE ROLLE	RODILLO
1	034.031/P	1	RULLO MTZ-135	ROLLER	ROULEAU	WALZE ROLLE	RODILLO
1	034.060/P	1	RULLO MTZ-150	ROLLER	ROULEAU	WALZE ROLLE	RODILLO
1	034.052/P	1	RULLO MTZ-170	ROLLER	ROULEAU	WALZE ROLLE	RODILLO
2	BUCFL204	2	SUPPORTO	SUPPORT	SUPPORT	LAGER	SOPORTE
3	30.02.00.010	10	DADO AUTOBLOCCANTE	STOP NUT	ECROU DE SURETE	SPERRMUTTER	TUERCA AUTOTRABADORA
4	15.1.0.00.010	6	RONDELLA	WASHER	RONDELLE	SCHEIBE	ARANDELA
5	21.0.0.10035	6	VITE	SCREW	VIS	SCHRAUBE	TORNILLO
6	031.030	1	SUPPORTO RULLO MTZ-100	SUPPORT	SUPPORT	LAGER	SOPORTE
6	034.006	1	SUPPORTO RULLO MTZ-120	SUPPORT	SUPPORT	LAGER	SOPORTE
6	034.030	1	SUPPORTO RULLO MTZ-135	SUPPORT	SUPPORT	LAGER	SOPORTE
6	034.060	1	SUPPORTO RULLO MTZ-150	SUPPORT	SUPPORT	LAGER	SOPORTE
6	034.051	1	SUPPORTO RULLO MTZ-170	SUPPORT	SUPPORT	LAGER	SOPORTE
7	21.0.0.10045	2	VITE	SCREW	VIS	SCHRAUBE	TORNILLO
8	031.032	1	PULISCI RULLO MTZ-100	ROLLER CLEANER	NETTOYEUR ROULEAU	WALZENREINIGER	LIMPIADOR RODILLO
8	034.015	1	PULISCI RULLO MTZ-120	ROLLER CLEANER	NETTOYEUR ROULEAU	WALZENREINIGER	LIMPIADOR RODILLO
8	034.032	1	PULISCI RULLO MTZ-135	ROLLER CLEANER	NETTOYEUR ROULEAU	WALZENREINIGER	LIMPIADOR RODILLO
8	034.061	1	PULISCI RULLO MTZ-150	ROLLER CLEANER	NETTOYEUR ROULEAU	WALZENREINIGER	LIMPIADOR RODILLO
8	034.053	1	PULISCI RULLO MTZ-170	ROLLER CLEANER	NETTOYEUR ROULEAU	WALZENREINIGER	LIMPIADOR RODILLO

Tav. 08.0

